

Specification

CombiMaster® Plus CMP XS 2/3 E (6 x 2/3 GN)

Reference number:



Description

- Hot-air steamer (combi-steamer mode) conforming to DIN 18866 for most of the cooking methods used in commercial kitchens for the optional use of steam and hot-air, individually, in succession or in combination.

Working safety

- Cleaning and rinse aid tabs (solids) for maximum operational safety
- HACCP data output and software update via integral USB port
- Safety temperature limiter for steam generator and hot-air heating
- Maximum rack height 5 1/4 ft. / 1.60 m when original stand used
- Integral fan impeller brake
- Door handle with right/left and slam function

Operation

- Mode selector control for cooking modes, separate controls for temperature, core temperature and time settings
- LED illuminated display, visible from a distance
- Clear control panel

Cleaning, care and operational safety

- 3 automatic cleaning programs
- Diagnostic system with automatic service notices displayed
- Menu-guided user descaling program

Features

- Rear-ventilated triple-glazed cooking cabinet door, two hinged inside panes (for easy cleaning) with a special heat-reflecting coating
- Unit base with surrounding seal
- Removable, swivel hinging rack with flexible rack options on 11 levels
- LED cooking cabinet lighting - energy-saving, durable and low-maintenance
- USB port
- Probe for core temperature measurement
- Individual programming of 100 cooking programs each with up to 6 steps
- 5 fan air speeds, programmable
- Integral, maintenance-free grease extraction system with no additional grease filter
- Cool-down function for fast cabinet fan cooling
- High-performance fresh steam generator
- Automatic, active rinsing and drainage of steam generator by pump
- Automatic adaptation to the installation location (height, climate, etc.)
- Seamless hygienic cooking cabinet with rounded corners, cabinet with splash guard - stops water from spilling out
- Material inside and out 304 (DIN 1.4301) stainless steel
- Hand shower with automatic retracting system
- Fixed waste water connection conforming to SVGW requirements where permitted
- Splash and hose-proof to IPX 5
- Temperature unit is selectable in °C or °F
- Dynamic air mixing

ClimaPlus



Climate management - humidity measurement, 5-stage setting and regulation

Combi-Steamer mode



Steam between 30 °C and 130 °C



Hot-air from 30 °C-300 °C



Combination of steam and hot-air
30 °C-300 °C

Approval/Labels



Planner/Designer:

CombiMaster® Plus CMP XS 2/3 E (6 x 2/3 GN)

Technical Info

Lengthwise loading for: 2/3, 1/2, 1/3 GN
Capacity (GN-container/ grids): 6 x 2/3 GN
Number of meals per day: 20-80
Width: 657 mm
Depth: 657 mm
Height: 897 mm
Weight (net): 62 kg

Weight (gross): 82 kg
Water connection (pressure hose): 3/4" / d 1/2"
Water pressure (flow pressure): 150-600 kPa / 0,15-0,6 Mpa / 1,5 - 6 bar
Water drain: DN 40 mm
Connected load electric : 5,7 kW
"Steam" connection: 5,4 kW

"Hot-air" connection: 5,4 kW

Mains connection	Breaker Size / (amp draw)	Cable crossection
3 NAC 400V 50/60Hz 1 NAC 230V 50Hz Other voltage on request!	3x10 A 1x25A (25 amps)	5 x 1,5 mm ² 3x4 mm ²

Installation

- Attention: Copper wiring only!
- Recommended left hand clearance for service and maintenance 20" / 500 mm. It must be a minimum of 14" / 350 mm if heat sources are affecting the left side of the unit
- Installations must comply with all local electrical, plumbing and ventilation codes

Options

- Left hinged door
- Interface Ethernet
- Safety door lock
- Connection to energy optimising systems + Potential free contact for operation indication included
- Special voltages
- external signal unit connection

Accessories

- UltraVent XS condensation hood
- Integration kit incl. UltraVent condensation hood
- GN Containers, Trays, Grids
- Wall mounting to mount the appliance
- CombiGrill®/Griddle grid
- Stand

CombiMaster® Plus CMP XS 2/3 E (6 x 2/3 GN)

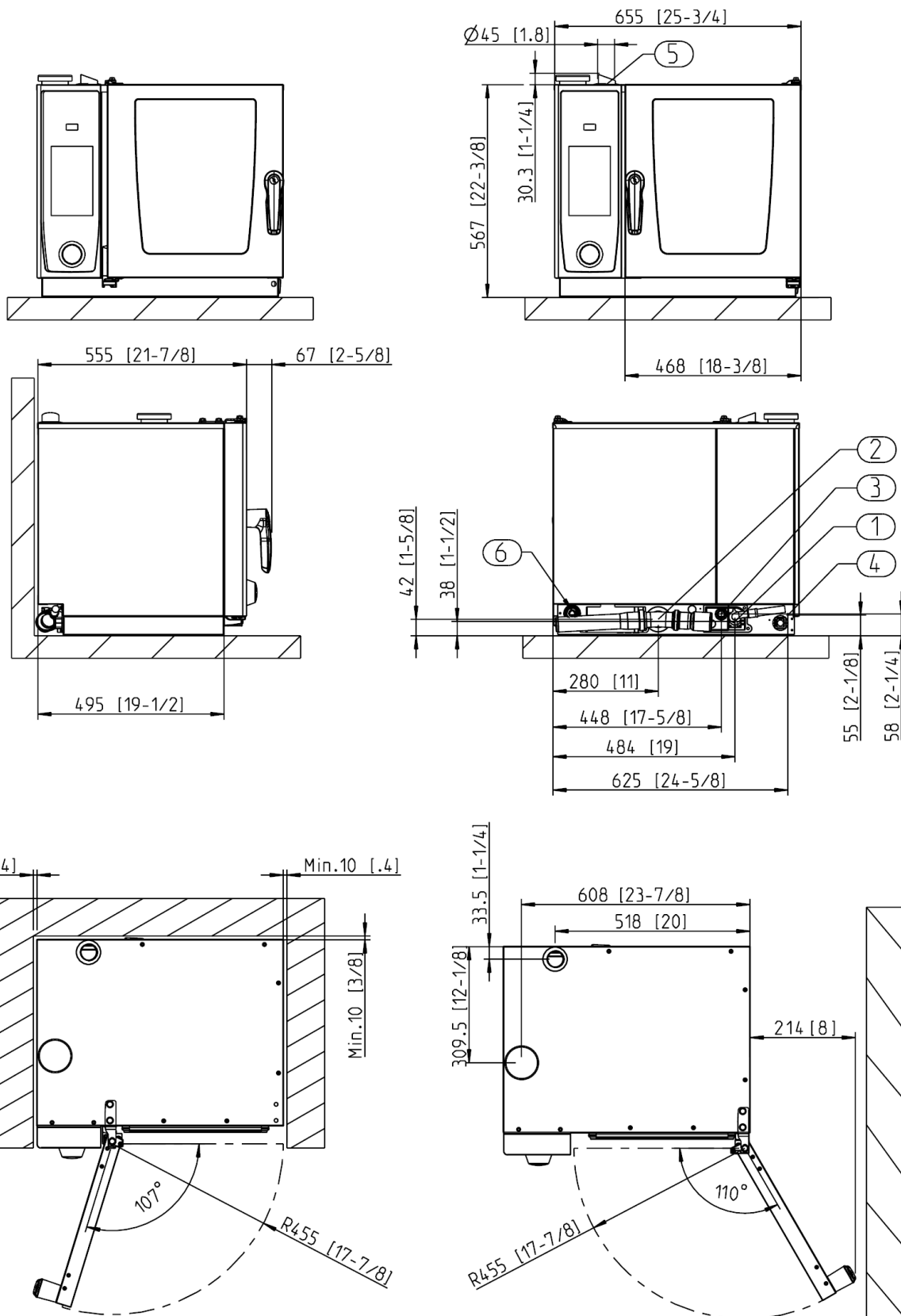

1. Common water supply (cold water) "Single" water connection as shipped 2. Drain 3. Electrical connection wire entrance 4. Chassis Ground connection 5. Steam Vent pipe 2 3/8" / 60mm Minimum Clearance 2" / 50 mm Left side clearance 20" recommended for servicing of unit without the ability to move unit while connected. Measurements in mm (inch)

RATIONAL UK

Unit 4 Titan Court, Laporte Way
Portenway Business Park, Luton LU4 8EF
Tel.: +44 (0) 1582 480388, Fax.: +44 (0) 1582 485001

Visit us on the internet: www.rational-online.uk

We reserve the right to make technical improvements